

Version	FPMEX36I6SS-R1 Plus - Island - 36" (90 cm) - 600 CFM
Design	Falmec Lab
Collection	Potenza

FEATURES AND PROPERTIES

Materials/Finishes	Stainless steel
Technology	SRS Speed reduction system
Control	Electronic control
Ducting type	External ducting/Recirculating
Installation type	Island
Lighting	Dynamic Light (2700K - 5600K) Strip LED
Filters	Metallic grease filter, removable and washable Charcoal filter (optional)
Dimensions	36 in
Notes	Recommended mounting height from cooking surface to hood bottom: 24" - 35"



Photograph is for information purposes only. May not correspond to the selected version

ELECTRICAL CONNECTION AND CONSUMPTION

Maximum consumption	340 W
Voltage/Frequency	110-120V 60Hz
Connection type	Hood comes standard with Nema 5-15P power cord

BLOWER PERFORMANCE

Motor	600 CFM
Minimum sound level	
Maximum sound level	0 dB (A)re1pW I.E.C. 60704-2-13

WEIGHTS AND DIMENSIONS

Gross weight	75 lbs
Net weight	62 lbs
Volume	13 ft
Packaging dimensions	L 41 x H 19 x D30 in

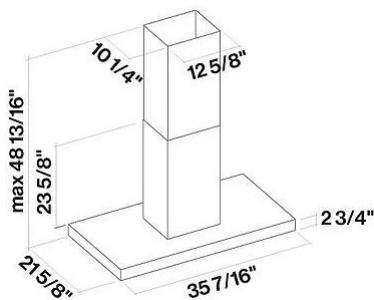

OPTIONAL ACCESSORIES

<i>Code</i>	<i>Description</i>
KACL.815	Protective cleaning cloths for stainless steel (box 10 pcs)
103050107	FFCHASQC0BL - Square charcoal filter - Type 3
KACL.510#3	Extension kit h700 - Inox
KACL.512#3	KIT ACC. :EXTENSION FM LINE H=960mm INOX

ENGINE SPECIFICATIONS

Motor speed

Noise dB(A) re1pW I.E.C. 60704-2-13

Capacity

Maximum pressure (Pa)

Motor power (W)

Air outlet

CAPACITY / PRESSURE

If activated SRS has 2 settings; 3 speed max & 2 speed max

TECNICAL SPECS OF COOKERHOOD WITH 600 CFM MOTOR

	SRS 2		SRS 3	
Motor Speed	1	2	3	4
CFM (rated at the motor)	210	295	395	600
Sones (estimated value)	1,5	3	4,25	6
Duct Size	6"	6"	6"	6"