

NSE6DG8300SRAC

6.3 cu. ft. Electric Slide-in Range with Wi-Fi and Air Fry



Signature Features

3.0 kW Electric Cooktop

Cook fast and evenly using the powerful heat of the 3.0 kW Electric Cooktop for convenient meals that taste delicious. This 5-burner cooktop includes 2 dual ring burners so you can cook with multiple sized pots and pans.

Air Fry

Enjoy healthier fried foods with Air Fry built right into your oven. Air Fry tray included.

Precision Knobs

Precisely control and ensure proper activation of your cooktop with integrated knob buttons that must be pinched in before the knobs can be pushed and turned.

Fan Convection

Fan Convection circulates air to cook food faster and more evenly than a conventional oven.

Available Colour



Stainless Steel



Air Fry

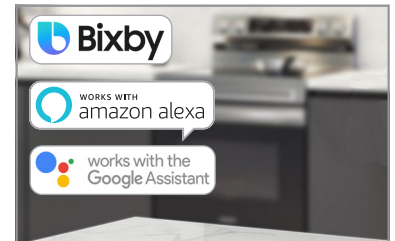

Wi-Fi Connectivity and Voice Control

Features

- Intelligent User Experience
- Fan Convection
- Bread Proof 95°F (35°C)
- Wi-Fi Connectivity
- Voice Control
- Bespoke Design
- Self and Steam Clean
- 3.0 kW Electric Cooktop
- SmartThings
- Fingerprint Resistant Finish
- Extra Large Oven Capacity
- Precision Knobs
- Storage Drawer
- Ready2Fit™ Guarantee

Convenience

- Smart Control
- Smart Install
- Sabbath Mode



(1) Available on Android and iOS Devices through the SmartThings App.

(2) A Wi-Fi connection is required.

(3) Bixby is Samsung's brand of artificial intelligence (AI) / Internet of Things (IoT) voice assistant. A Samsung account is required.

NSE6DG8300SRAC

6.3 cu. ft. Electric Slide-in Range with Wi-Fi and Air Fry

Installation Specifications

IMPORTANT: To eliminate the risk of burns or fire caused by reaching over heated surface units, avoid having cabinet storage space located above the surface units. If you have cabinet storage space over the heating elements, you can reduce the risk by installing a range hood that projects horizontally a minimum of 5 inches beyond the bottom of the cabinets.

* A minimum of 30" is required between the top of the cooking surface and the bottom of an unprotected wood or metal cabinet; a minimum of 24" is required if the bottom of the wood or metal cabinet is protected by not less than 1/4" of flame retardant millboard covered with not less than no.28 MSG of sheet steel, 0.015" of stainless steel, 0.024" of aluminum, or 0.020" of copper.

** A minimum of 15" is required between the countertop and the adjacent cabinet bottom.

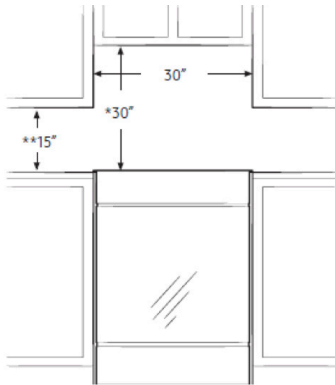

SLIDE-IN CUTOUT

Dimensions

CAUTION: This range has been designed to comply with the maximum allowable wood cabinet temperatures of 194°F. Make sure the wall covering, countertops, and cabinets around the range can withstand the heat (up to 194 °F) generated by the range. If not, discolouration, delamination, or melting may occur.

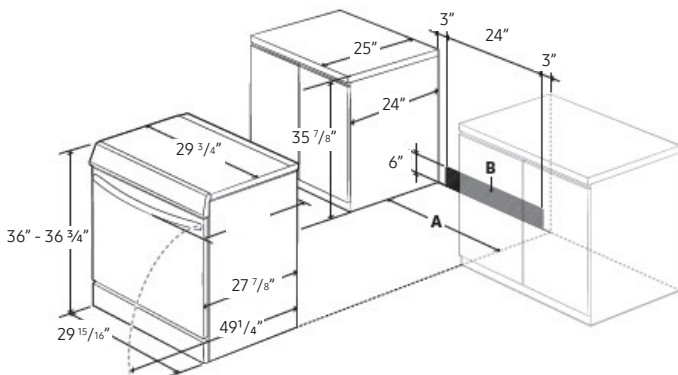

Power Source

Range rating, watts		Specified rating of power-supply-cord kit and circuit protection, Amps	Diameter (inch) of range connection opening	
120/240 volts 3-wire	120/240 volts 3-wire		Power cord	Conduit
8750-16500	7801-12500	40 or 50 A	1 3/8"	1 1/8"

Radiant Ceramic Cooktop

Right Front: 9"/12" - 3000W

Left Front: 6"/9" - 3000W

Right Rear: 6" - 1200W

Left Rear: 6" - 1200W

Center Rear: 6" Warm Zone (100W)

Oven: 6.3 cu. ft. Capacity

Bake Element: 3000W

Broil Element: 4200W

Bake: 175°F - 550°F

Convection Bake: 175°F - 550°F

Convection Roast: 175°F - 550°F

Air Fry: 350°F - 500°F

Storage Drawer

Capacity: 0.9 cu. ft.

Warranty

One (1) Year Parts and Labour

Product Dimensions & Weight (WxHxD)

Outside Net Dimensions: 29¹⁵/₁₆" x 36" - 36³/₄" x 27⁷/₈"

Net Weight: 160.5 lb (72.8 kg)

Shipping Dimensions & Weight (WxHxD)

Dimensions: 33¹/₁₆" x 41¹/₈" x 30⁵/₁₆"

Shipping Weight: 180.12 lb (81.7 kg)

Colour

Stainless Steel

Model

NSE6DG8300SRAC

UPC

887276821597