

# 24" Series 9 Contemporary Self-Cleaning Oven

Series 9 | Contemporary



A highlight of the Fisher & Paykel collection, this Series 9 oven with touchscreen guided cooking helps to ensure every dish is cooked to perfection.

- Touchscreen guided cooking capability offers helpful tips for different food types as well as full recipes
- 3 cu ft total capacity, with 16 oven functions including Pastry Bake, Roast, Air Fry and Dehydrate
- Moisture level control with ActiveVent technology
- Pyrolytic self-cleaning function breaks down food residue for an easy clean

## DIMENSIONS

|        |           |
|--------|-----------|
| Height | 23 9/16 " |
| Width  | 23 7/16 " |
| Depth  | 22 1/4 "  |

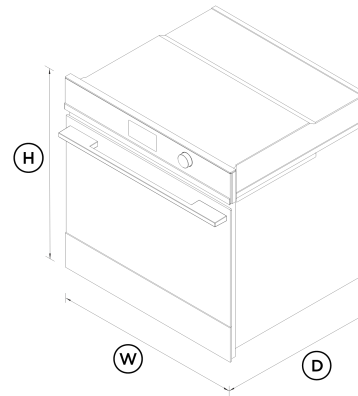

## FEATURES & BENEFITS

### Cook With Confidence

Using the large 5" touchscreen interface, you can cook with a favourite method, a hero ingredient, or a go-to cooking function or recipe. Your oven will guide you through the steps, or change the temperature and heat type automatically, depending on your selection.

### Generous Capacity

With an exceptional 3 cu ft total capacity, you can create several perfectly cooked dishes at once using multiple shelves. Non-tip, full-extension shelves help to ensure safe removal of hot dishes.

### Exceptional Performance

Our unique cooking technologies were developed to deliver perfect results. ActiveVent ensures optimized moisture levels, while AeroTech™ circulates heat evenly for a consistent temperature.

### Safe And Sound

The CoolTouch door of this built-in oven is safe to touch from the outside. Sturdy, fully extendable shelves slide all the way out, reducing the need for you to reach inside.

### Self-Cleaning

Pyrolytic self-clean breaks down food residue at a very high temperature, leaving a light ash that's easily removed with a damp cloth. The enamel coated side racks don't need to be removed when using this function.

### Design Freedom

Designed to fit seamlessly into your kitchen, this built-in oven features premium materials and detailing to support a cohesive, considered kitchen design.

### Multi-Function Flexibility

Each function has been tailored, tested and perfected to ensure that no matter what you're cooking, you've got the right heat to match. Purchase our Wireless Temperature Sensor accessory and precisely monitor cooking in real time (accessory sold separately).

## SPECIFICATIONS

### Accessories (included)

Broil grid

1

|                                |       |
|--------------------------------|-------|
| Broil pan                      | 1     |
| Broil rack                     | 1     |
| Full extension sliding shelves | 1 set |
| Pyrolytic proof shelf runners  | •     |
| Step down wire shelf           | 1     |
| Wired temperature sensor       | 1     |

**Capacity**

|                 |           |
|-----------------|-----------|
| Shelf positions | 6         |
| Total capacity  | 3 cu ft   |
| Usable capacity | 2.5 cu ft |

**Cleaning**

|                                 |   |
|---------------------------------|---|
| Acid resistant graphite enamel  | • |
| Pyrolytic proof shelf runners   | • |
| Pyrolytic self-clean            | • |
| Removable oven door             | • |
| Removable oven door inner glass | • |
| Removable shelf runners         | • |

**Controls**

|                                       |   |
|---------------------------------------|---|
| Adjustable audio and display settings | • |
| Automatic cooking/minute timer        | • |
| Automatic pre-set temperatures        | • |
| Celsius/Fahrenheit temperature        | • |
| Delay start                           | • |
| Electronic clock                      | • |
| Electronic oven control               | • |

|   |  |
|---|--|
| Food probe  | •  |
| Guided cooking by food type and recipes             | •  |
| Internal Light                                      | •  |
| Intuitive touchscreen display                       | •  |
| Multi-language display                              | •  |
|   | <b>UK English, US English, Simplified Chinese, Français, Español</b> |
| Sabbath mode with Star K certification              | •  |
| Smart appliance                                     | •  |
| Soft close doors                                    | •  |
| True convection oven                                | •  |
| Turned stainless steel dials with illuminated halos | •  |

**Functions**

|                      |    |
|----------------------|----|
| Aero Broil           | •  |
| Aero™ Bake           | •  |
| Air fry              | •  |
| Bake                 | •  |
| Broil                | •  |
| Classic bake         | •  |
| Dehydrate            | •  |
| Number of functions  | 16 |
| Pastry Bake          | •  |
| Pizza bake           | •  |
| Pyrolytic self-clean | •  |
| Rapid proof          | •  |
| Roast                | •  |
| Slow cook            | •  |
| True Aero            | •  |

|           |   |
|-----------|---|
| Vent bake | • |
| Warm      | • |

**Performance**

|                          |                |
|--------------------------|----------------|
| ActiveVent™ system       | •              |
| AeroTech™ technology     | •              |
| Automatic rapid pre-heat | •              |
| Temperature range        | 95 °F - 540 °F |

**Power Requirements**

|                  |               |
|------------------|---------------|
| Amperage         | 16.6 - 19.4 A |
| Supply frequency | 60 Hz         |
| Supply voltage   | 208 - 240 V   |

**Product Dimensions**

|        |           |
|--------|-----------|
| Depth  | 22 1/4 "  |
| Height | 23 9/16 " |
| Width  | 23 7/16 " |

**Safety**

|                          |   |
|--------------------------|---|
| ADA compliant            | • |
| Balanced oven door       | • |
| Catalytic venting system | • |
| Control panel key lock   | • |
| CoolTouch door           | • |
| Non-tip shelves          | • |
| Safety thermostat        | • |

SKU 82525

---

The product dimensions and specifications in this page apply to the specific product and model. Under our policy of continuous improvement, these dimensions and specifications may change at any time. You should therefore check with Fisher & Paykel's Customer Care Centre to ensure this page correctly describes the model currently available. © Fisher & Paykel Appliances Ltd 2020

Our In-use Energy Carbon Emissions Estimate is designed to assist customers in making informed purchasing decisions when comparing different Fisher & Paykel products. For example, a heat pump dryer typically has a lower In-use Energy Carbon Emissions Estimate than a vented dryer.



**A PEACE OF MIND SALE**  
**24 Hours 7 Days a Week Customer Support**

T 1.888.936.7872 W [www.fisherpaykel.com](http://www.fisherpaykel.com)

#### Other product downloads available at [fisherpaykel.com](http://fisherpaykel.com)

- [↓ 2D-DWG Oven](#)
- [↓ 2D-DXF Oven](#)
- [↓ ArchiCAD Oven](#)
- [↓ Datasheet Oven](#)
- [↓ Installation Guide Wall Oven EN](#)
- [↓ Guide d'installation FR](#)
- [↓ Installation Guide SP](#)
- [↓ Revit Oven](#)
- [↓ Rhino Oven](#)
- [↓ SketchUp Oven](#)
- [↓ User Guide Oven EN](#)
- [↓ User Guide Oven FR](#)
- [↓ User Guide Oven SP](#)

#### Where applicable:

All appliances use energy, and energy usage typically generates carbon emissions. **Fisher & Paykel Appliances' In-use Energy Carbon Emissions Estimate** indicates carbon emissions from a product's in-use energy. This is calculated either annually or per cycle, using the product's market-specific energy label energy consumption data multiplied by the carbon emissions factor for energy in your country or region.