

24" Series 7 Contemporary Compact Convection Speed Oven

Series 7 | Contemporary



The speed of microwave cooking with the versatility of convection oven technology in a compact companion model.

- Compact size, and generous 1.7 cu ft capacity with four shelf positions
- Intuitive, 2.4" display with illuminated dial
- Use the optional trim kit to integrate this microwave with your cabinetry
- Wi-Fi enabled and works with the SmarHq™ app for remote control and notifications

DIMENSIONS

Height	18 "
Width	23 7/16 "
Depth	22 1/4 "

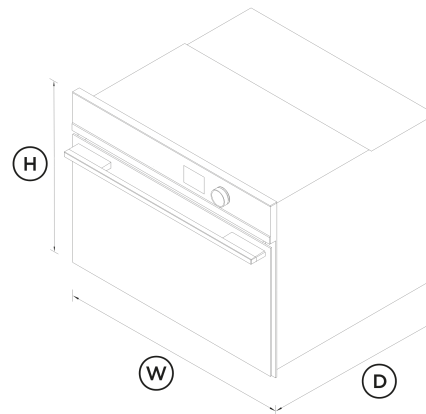

FEATURES & BENEFITS

Cooking Flexibility

Choose from 19 functions including True Convection and Broil. With both microwave and convection oven technology in the same oven, you have more flexibility for your culinary creations.

Sized To Suit

A compact 24" width means this microwave oven can be placed almost anywhere – all companion products can be installed at a convenient height to suit your kitchen design and preference.

Easy To Use

The intuitive display shows you all the information you need, allowing you to easily program in your desired cooking mode and duration.

Complementary Design

Finished in a stylish stainless steel, our Contemporary style companion products help you achieve a coherent kitchen aesthetic that suits your design style.

Easy Cleaning

This Convection Speed Oven features easily removable side racks and an enamel interior for easy cleaning.

Safe And Sound

The CoolTouch door is safe to touch from the outside, protecting your hands and the surrounding cabinetry.

SPECIFICATIONS

Accessories (included)

Broil rack	1
Glass tray	1
Step down wire shelf	1
Wire shelf	1

Accessories (sold separately)

Matching Trim Kit	TK7630NDB1
-------------------	------------

Capacity	
Shelf positions	4
Total capacity	1.7 cu ft
Usable capacity	1.3 cu ft

- Soft close doors
- True convection oven
- Turned stainless steel dials with illuminated halos

Performance	
ActiveVent™ system	•
AeroTech™ technology	•
Automatic rapid pre-heat	•
Grill power	3000 W
Microwave power	900 W
Microwave power levels	6
Temperature range	35 - 230°C
Whisper Quiet Cooking	•

Cleaning	
Acid resistant graphite enamel	•
Drying cycle	•
Easy to clean interior	•
Removable shelf runners	•

- | | |
|-------------------------------|-----------|
| Functions | |
| Aero Broil | • |
| Aero Pastry | • |
| Aero™ Bake | • |
| Air fry | • |
| Bake | • |
| Broil | • |
| Convection bake | • |
| Defrost | • |
| Dehydrate | • |
| Fan forced + Micro (3 levels) | • |
| Fan grill + Micro (3 levels) | • |
| Grill + Micro (3 levels) | • |
| Maxi Broil | • |
| Microwave cooking | • |
| Number of functions | 19 |
| Pastry Bake | • |
| Pizza bake | • |
| Popcorn | • |
| Quick start | • |
| Roast | • |
| Roast + Micro (3 levels) | • |
| Slow cook | • |
| True Aero | • |
| Vent bake | • |
| Warm | • |

Power Requirements	
Amperage	23 A
Supply frequency	60 Hz
Supply voltage	208 - 240 V

Controls	
Adjustable audio and display settings	•
Audio feedback	•
Automatic cooking/minute timer	•
Automatic pre-set temperatures	•
Celsius/Fahrenheit temperature	•
Delay start	•
Electronic capacitive touch controls	•
Electronic clock	•
Electronic oven control	•
Guided cooking	•
Internal Light	•
LED display	•
Microwave timer	•
Multi-language display	true
Push-to-open drawer	•
Sabbath mode with Star K certification	•
Smart appliance	•

Product Dimensions	
Depth	22 1/4 "
Height	18 "
Width	23 7/16 "

Safety	
ADA compliant	•
Balanced oven door	•
Control panel key lock	•
CoolTouch door	•
Non-tip shelves	•
Safety thermostat	•

SKU

82705



A PEACE OF MIND SALE
24 Hours 7 Days a Week Customer Support
T 1.888.936.7872 W www.fisherpaykel.com

The product dimensions and specifications in this page apply to the specific product and model. Under our policy of continuous improvement, these dimensions and specifications may change at any time. You should therefore check with Fisher & Paykel's Customer Care Centre to ensure this page correctly describes the model currently available. © Fisher & Paykel Appliances Ltd 2020

Other product downloads available at fisherpaykel.com

- [↓](#) Combination Speed Oven
- [↓](#) 2D-DWG Convection Speed Oven
- [↓](#) 2D-DXF Combination Speed Oven
- [↓](#) 2D-DXF Convection Speed Oven
- [↓](#) Planning Guide Contemporary Combination Speed Oven
- [↓](#) User Guide EN
- [↓](#) User Guide FR
- [↓](#) User Guide SP

Where applicable:

All appliances use energy, and energy usage typically generates carbon emissions. **Fisher & Paykel Appliances' In-use Energy Carbon Emissions Estimate** indicates carbon emissions from a product's in-use energy. This is calculated either annually or per cycle, using the product's market-specific energy label energy consumption data multiplied by the carbon emissions factor for energy in your country or region.

Our In-use Energy Carbon Emissions Estimate is designed to assist customers in making informed purchasing decisions when comparing different Fisher & Paykel products. For example, a heat pump dryer typically has a lower In-use Energy Carbon Emissions Estimate than a vented dryer.