



## Steel Seal™ Washing machine

W5XLG.U

**Series 5**

**Loading capacity: 11 kg**

**1400 rpm**

**Number of programs: 28**

**Installation: Freestanding**

### Programs

- Programmes: Normal cotton, Time program, Mix/synthetic, Wool/hand wash, Jeans, Beddings / Towels, Shirts / Blouses, Down, Waterproofing, Outerwear, Colored laundry, White laundry, Universal wash, Delicates
- Special washing programs: Quick Pro, Steam refresh, Allergy program Synthetics, Allergy program Cotton, SportWash
- Special functions: Drum cleaning, Spin, Drain, Rinse
- Wi-Fi washing programs: Baby clothes, Textile trainers, Soft toys, Underwear, Swimwear
- Modes: Normal - No changes to the program, Green - Saves water and energy. Program time slightly longer, Speed mode - More water and energy used to ensure a clean laundry in shorter time, Intensive mode - Improved cleaning with more water and energy. Temperature is kept at high level for longer

### Additional options

- Temperature range: Cold - 90 °C
- Spin speed setting: Adjustable
- Max spin speed: 1400 rpm
- Delayed start: Up to 24 hours
- Settings: Prewash, No spin, High water level, Super rinse, Small load option, Steam disinfection, Delayed Start, Add clothes

### Construction and performance

- Door sealing: Steel Seal™ - Hygienic sealing without rubber bellow
- Quattro Construction™ : Yes, 2.0 Professional suspension with motorized door lock to minimize noise and vibrations
- Outer drum: Stainless Steel
- Inner drum: Stainless Steel
- Counter weight material: Cast iron
- Counterweight: 17 kg
- Active Drum™ - Ensure a gentle yet effective washing cycle: Yes
- Max +/- 1 °C temperature variation: Yes
- Drum volume: 2.8 Cubic ft
- Door hinge placement: Left
- Door opening diameter: 310 mm
- Door maximum opening angle: 110 °
- Motor: Long life and quiet brushless motor
- Shortest program time: 20 min

### Use and flexibility

- Easy Close door: Yes
- Easy door opening: Yes
- Door lock: Motorized
- Stop flap for Liquid detergent: Yes
- Automatic detergent drawer cleaning: Time remaining indicator
- Load Light™ - Illumination of the drum: Yes
- Automatic dosing system: Yes, with detergent and fabric conditioner
- Dose assist: Yes
- Wifi: Yes
- ConnectLife: Monitoring and control in the palm of your hand: ConnectLife
- Bluetooth: Yes
- Included accessory: Discharge hose bow

### Interaction and control

- Remaining time indicator: Yes

- Type of display: TFT - Full colour touch display (possible to interact with jog dial as well)
- Transparent door cover/Double glass door: No
- Number of programs: 28
- Create own program: Yes
- Language settings: Swedish, Slovenian, Slovak, Russian, Polish, Norwegian, Dutch, Latvian, Lithuanian, Japanese, Italian, Croatian, French, Finnish, Estonian, Spanish, English, German, Danish, Czech, US English, Ukrainian, Serbian, Portuguese, AU English

#### **Design and integration**

- Main colour of product: Graphite black
- ASKO dryer and washer can be easily stacked.: Yes
- Loading type: Front load
- Adjustable feet: 10 mm

#### **Safety and maintenance**

- Waterproof base with leakage detection: Yes
- Maximized water inlet time: Yes
- Aqua safe system: Yes, with bottom sensor
- Water inlet hose: Aqua stop, shuts off water if it leaks
- Drain system: Anti Block™ - Self-cleaning drain pump
- Overflow protection: Yes
- Emergency door opening function: Yes
- Child lock on display: Yes
- Unbalance detection - Protects the washer against harmful vibrations: Yes
- Draining capacity: 20 l/min
- Overheat protection: For motor and electronics

#### **Technical data**

- Loading capacity: 11 kg
- Plug type: USA
- Connected load: 2200 W
- Voltage (V): 208-240 V
- Number of phases: 1
- Fuse: 15 A
- Frequency: 60 Hz
- Heater power: 2000 W
- Net weight: 99.2 kg
- Water connection: Cold water
- ISO 14001 certified manufacturing: Yes

#### **Dimensions**

- Width: 595 mm
- Height: 850 mm
- Depth: 687 mm
- Depth with door open: 1129 mm
- Length of electrical cord: 2100 mm
- Length inlet hose: 150 cm
- Length outlet hose: 160 cm

#### **Logistic information**

- Packaging width: 636 mm
- Packaging height: 920 mm
- Packaging depth: 776 mm
- Gross weight: 102.6 kg
- Weight of packaging: 3.4 kg
- Product code: 746442
- EAN code: 3838783003638

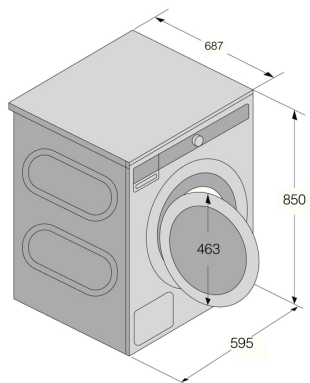

WMB60LJ, Cold and warm water inlet

