



## Steel Seal™ Washing machine

W5XLT.U

**5-series**

**Loading capacity: 24.3 lb**

**1400 rpm**

**Number of program: 28**

**Installation: Freestanding**

### Programs

- Programmes: Normal cotton, Time program, Mix/synthetic, Wool/hand wash, Jeans, Waterproofing, Down, Beddings / Towels, Shirts / Blouses, Outerwear, Colored laundry, White laundry, Universal wash, Delicates
- Special washing programs: Quick Pro, Steam refresh, Allergy program Synthetics, Allergy program Cotton, SportWash
- Special functions: Drum cleaning, Spin, Drain, Rinse
- Wi-Fi washing programs: Baby clothes, Textile trainers, Soft toys, Underwear, Swimwear
- Modes: Normal - No changes to the program, Green - Saves water and energy. Program time slightly longer, Speed mode - More water and energy used to ensure a clean laundry in shorter time, Intensive mode - Improved cleaning with more water and energy. Temperature is kept at high level for longer

### Additional options

- Temperature range: 194 °F
- Spin speed setting: Adjustable
- Max spin speed: 1400 rpm
- Delayed start: Up to 24 hours
- Settings: Prewash, No spin, High water level, Super rinse, Small load option, Steam disinfection, Add clothes, Pause

### Construction and performance

- Door sealing: Steel Seal™ - Hygienic sealing without rubber bellow
- Quattro Construction™ : Yes, 2.0 Professional suspension with motorized door lock to minimize noise and vibrations
- Tub: Stainless Steel
- Inner drum: Stainless Steel
- Counter weight material: Cast iron
- Counterweight: 37.5 lb
- Active Drum™ - Ensure a gentle yet effective washing cycle: Yes
- Max +/- 1 °F temperature variation: Yes
- Drum volume: 2.8 Cubic ft
- Door hinge placement: Left
- Door opening diameter: 12 3/16 "
- Door maximum opening angle: 110 °
- Motor: Long life and quiet brushless motor
- Shortest program time: 20 min

### Use and flexibility

- Easy Close door: Yes
- Easy door opening: Yes
- Door lock: Motorized
- Stop flap for Liquid detergent: Yes
- Automatic detergent drawer cleaning: Time remaining indicator
- Load Light™ - Illumination of the drum: Yes
- Automatic dosing system: Yes, with detergent and fabric conditioner
- Dose assist: Yes
- Wifi: Yes
- ConnectLife: Monitoring and control in the palm of your hand: ConnectLife
- Bluetooth: Yes
- Included accessory: Discharge hose bow

### Interaction and control

- Remaining time indication: Yes

- Type of display: TFT - Full colour touch display (possible to interact with jog dial as well)
- Transparent door cover/Double glass door: No
- Number of program: 28
- Create own program: Yes
- Language settings: Swedish, Slovenian, Slovak, Russian, Polish, Norwegian, Dutch, Latvian, Lithuanian, Japanese, Italian, Croatian, French, Finnish, Estonian, Spanish, English, German, Danish, Czech, US English, Ukrainian, Serbian, Portuguese, AU English

#### **Design and integration**

- Main color of product: Titanium
- Easy mounting of ASKO dryer on top of the washers: Yes
- Loading type: Front load
- Adjustable feet: 3/8 "

#### **Safety and maintenance**

- Waterproof bottom plate with leakage detection: Yes
- Maximized water inlet time: Yes
- Aqua safe system: Yes, with bottom sensor
- Water inlet hose: Aqua stop, shuts off water if it leaks
- Drain system: Anti Block™ - Self-cleaning drain pump
- Overflow protection: Yes
- Emergency door opening function: Yes
- Child lock on display: Yes
- Unbalance detection - Protects the washer against harmful vibrations: Yes
- Draining capacity: 5.3 gal/min
- Overheat protection: For motor and electronics

#### **Technical data**

- Loading capacity: 24.3 lb
- Plug type: USA
- Connected load: 2200 W
- Voltage (V): 208-240 V
- Number of phases: 1
- Fuse: 15 A
- Frequency: 60 Hz
- Heater power: 2000 W
- Net weight: 218.3 lb
- Water connection: Cold water
- ISO 14001 certified manufacturing: Yes

#### **Dimensions**

- Width: 23 7/16 "
- Height: 33 7/16 "
- Depth: 27 1/16 "
- Depth with door open: 44 7/16 "
- Length of electrical cord: 82 11/16 "
- Length inlet hose: 59 1/16 "
- Length outlet hose: 63 "

#### **Logistic information**

- Packaging width: 25 1/16 "
- Packaging height: 36 1/4 "
- Packaging depth: 30 9/16 "
- Gross weight: 225.8 lb
- Weight of packaging: 7.5 lb
- Product code: 746337
- EAN code: 3838783001481

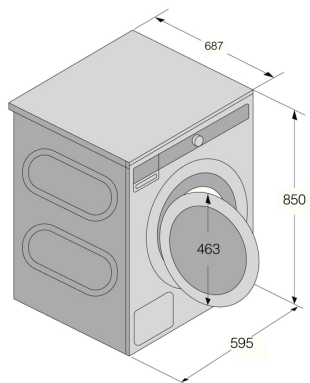

WMB60LJ, Cold and warm water inlet

